

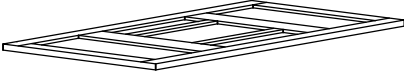



ASSEMBLY INSTRUCTION FOR ACME FURNITURE





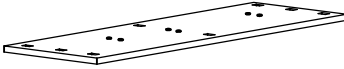

MODEL #DN02905-1 / DN02905-2

Thank you for purchasing the quality product. Be sure to check all packing material carefully for small parts which may have come loose inside the carton during shipment. Seperate, identify and count all parts and metal hardware. Compare with all parts list to be sure all parts are present. If any part(s) are missing or damaged, please contact your local furniture dealer. For efficient and speedy service, please indicate the model number and code letter of part(s) needed.

***** Do not fully tighten screws until assembled *****

COMPONENT PARTS			
DESCRIPTION	PART NAME		QTY (PCS)
①		TABLE TOP	1
②		TABLE LEG	2
③		MOUNTING PLATE	2
④		CROSS BAR	2

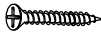
HARDWARE REQUIRED

Ⓐ		JCBC Bolt	M6 x 35MM	12 PCS
Ⓑ		JCBC Bolt	M6 x 40MM	16 PCS
Ⓒ		SPRING WASHRER	Ø1/4"	28 PCS
Ⓓ		FLAT WASHER	Ø1/4"	16 PCS
Ⓔ		CB SCREW	M4 x 32MM	4 PCS
Ⓕ		CB SCREW	M4 x 50MM	4 PCS
Ⓖ		ADJUSTER	M6 x 25MM	4 PCS
Ⓕ		ALLEN KEY	M4 x 65MM	1 PC

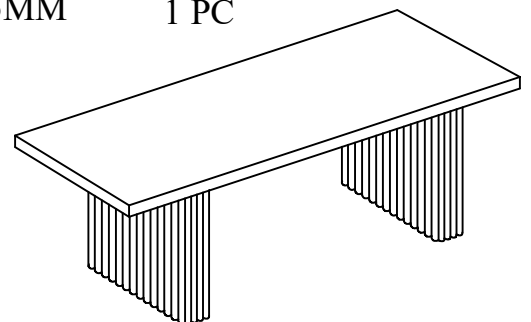

Attention

*** Some number parts listed on the Instruction sheet may not be in parts bag as they may already be assembled. Carefully check parts and packing materials prior to ordering replacements.

How to assemble:

STEP 1

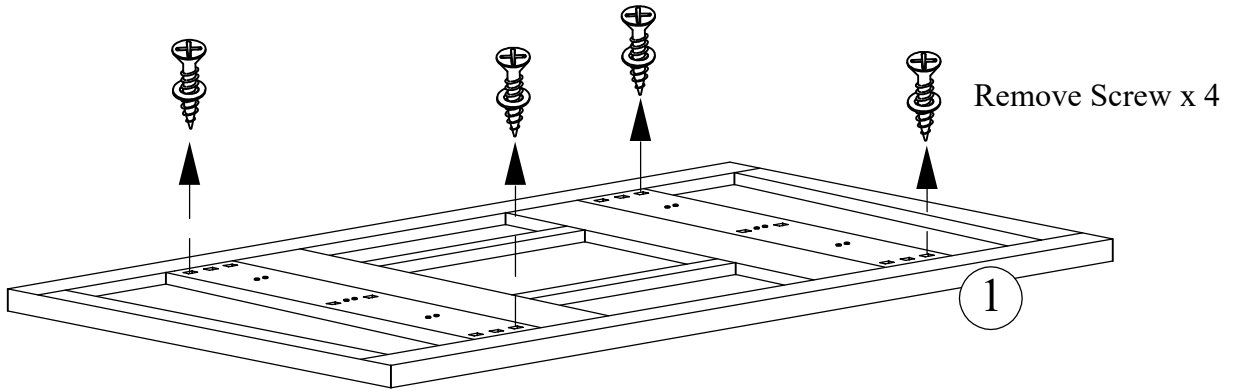

STEP 2

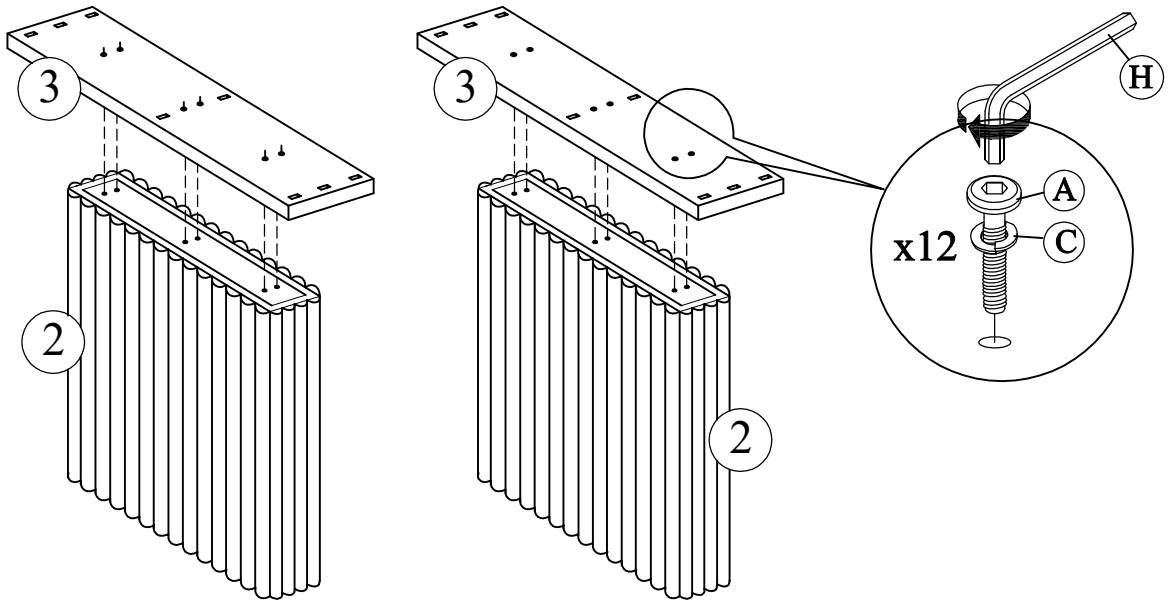

STEP 3

